

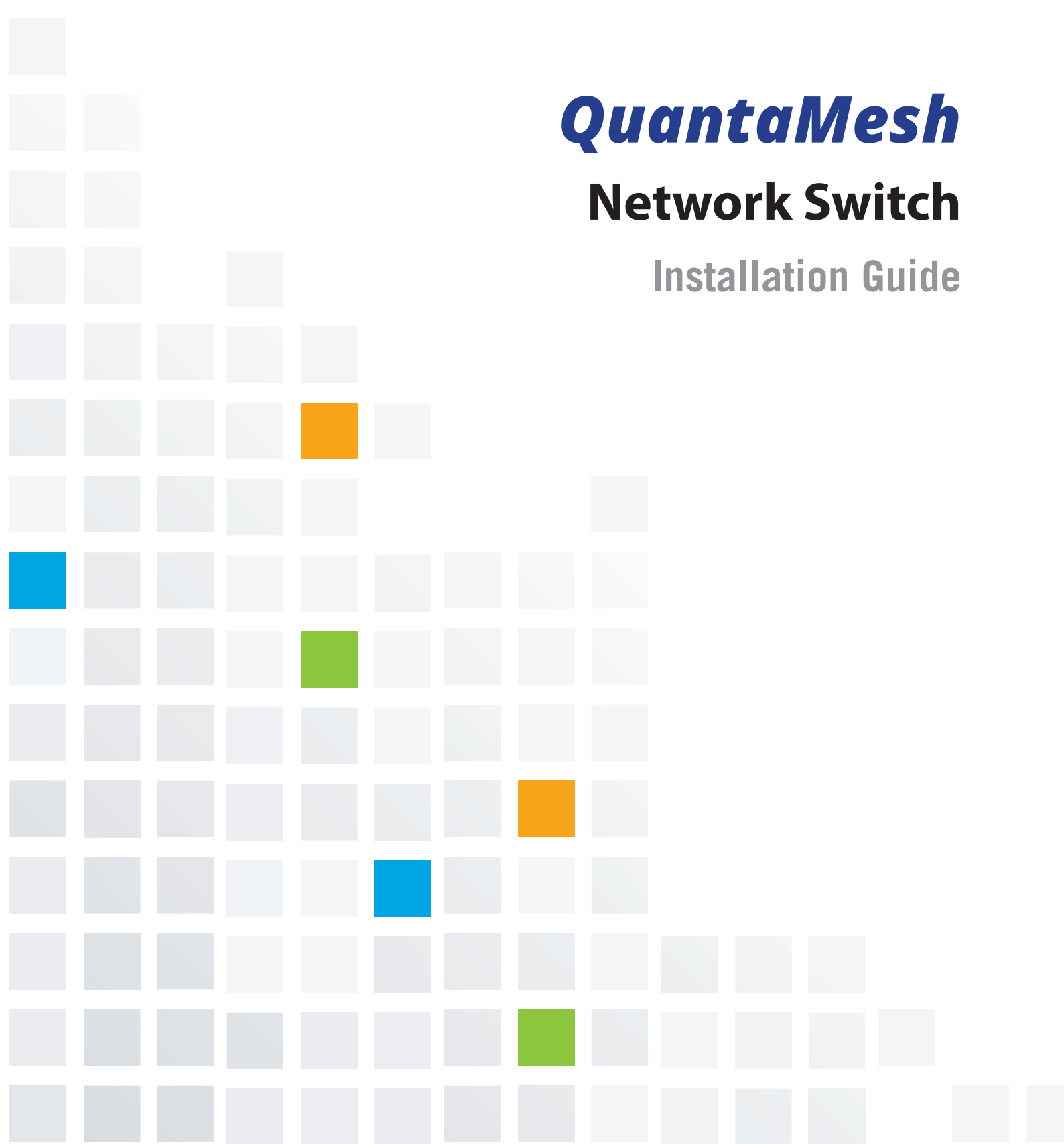

QuantaMesh

Network Switch

Installation Guide



SAFETY & REGULATORY INFORMATION

Copyright

All specifications and figures are subject to change without prior notice. Actual products may look different from the photos.

All trademarks and logos mentioned in this guide are the properties of their respective holders.

Copyright © 2017 Quanta Computer Inc. All rights reserved.

About the Manual

This installation guide is meant for network administrators with inept knowledge in network management.

To avoid personal injury or property damage, before you begin installing the product, read, observe, and adhere to all the following safety instructions and information.

The following symbols are used throughout the guide to highlight important information and may be marked on the product and / or the product packaging.



NOTE

Indicates useful information.



WARNING

Indicates safety information that if ignored may cause the system to malfunction or damage other equipment.



CAUTION

Indicates safety information that if ignored may cause personal injury or death.

Intended Application Uses

This product was evaluated as Information Technology Equipment (ITE), which may be installed in offices, schools, computer rooms, and similar commercial type locations. The suitability of this product for other product categories and environments (such as medical, industrial, residential, alarm systems, and test equipment), other than an ITE application, may require further evaluation.

Safety Information

Switch Safety Information

To reduce the risk of body injury, electrical shock, fire, and equipment damage, read this document and observe all warnings and precautions before installing or maintaining your switch.

In the event of a conflict between the information in this document and the information provided with the product or on the website of a particular product, the product documentation takes precedence.

The switch should be integrated and serviced only by technically qualified persons.

You must adhere to the guidelines in this guide and the assembly instructions in the switch manuals to ensure and maintain compliance with existing product certifications and approvals. Use only the described, regulated components specified in this guide. Use of other products / components will void the UL Listing and other regulatory approvals of the product, and may result in noncompliance with product regulations in the region(s) in which the product is sold.

Follow the safety guidelines below to ensure personal safety and protect the system and the working environment from potential damage.

**CAUTION**

- The power supplies in the system may produce high voltages and energy hazards which can cause bodily harm. Do not remove the covers and access any of the components inside the system.
- To reduce the risk of electrical shock, disconnect all power supply cables before servicing the system.
- Do not use the mounted equipment as a shelf or a work space.
- **Restricted Access Location:** The switch is intended for installation only in a Server Room or Computer Room where both these conditions apply:
 - ✓ access can only be gained by SERVICE PERSONS or by USERS who have been instructed about the reasons for the restrictions applied to the location and about any precautions that shall be taken; and
 - ✓ access is through the use of a TOOL or lock and key, or other means of security, and is controlled by the authority responsible for the location.

**WARNING**

When a power supply needs replacement, replace the power supply only with the same or equivalent type recommended by the manufacturer. Replacing with an incorrect power supply may cause explosion.

- Observe and follow service markings. Do not service the product yourself. Components inside the system should only be serviced by trained service technician.
- If any of the following conditions occur, unplug the equipment from the electrical outlet and replace the part or contact a trained service technician:
 - ✓ The power cable, extension cable, or plug is damaged
 - ✓ The equipment has been exposed to water
 - ✓ The equipment has been dropped or damaged
 - ✓ The equipment does not operate correctly when you follow the operating instructions
- Do not spill food or liquid on the equipment.
- Never operate the equipment in a wet environment.
- Do not push any objects into the opening of the equipment. Doing so may short internal components and cause fire or electric shock.
- Use the system only with approved equipment.
- Allow the product to cool before removing any peripherals.
- Operate the equipment only from the type of external power source indicated on the electrical ratings label. If you are unsure of the type of power source required, consult your local power company.
- Use only approved power cable(s).
- To help prevent electric shock, plug the system and peripheral power cables into properly grounded electrical outlets. Do not use adapter plugs or remove the grounding prong from a cable. If you must use an extension cable, use an extension cable with properly grounded plugs.
- Observe and follow service markings. Do not service the product yourself. Components inside the system should only be serviced by trained service technician.
- If any of the following conditions occur, unplug the equipment from the electrical outlet and replace the part or contact a trained service technician:
 - ✓ The power cable, extension cable, or plug is damaged
 - ✓ The equipment has been exposed to water
 - ✓ The equipment has been dropped or damaged
 - ✓ The equipment does not operate correctly when you follow the operating instructions
- Do not spill food or liquid on the equipment.
- Never operate the equipment in a wet environment.

SAFETY & REGULATORY INFORMATION

- Do not push any objects into the opening of the equipment. Doing so may short internal components and cause fire or electric shock.
- Use the system only with approved equipment.
- Allow the product to cool before removing any peripherals.
- Operate the equipment only from the type of external power source indicated on the electrical ratings label. If you are unsure of the type of power source required, consult your local power company.
- Use only approved power cable(s).
- To help prevent electric shock, plug the system and peripheral power cables into properly grounded electrical outlets. Do not use adapter plugs or remove the grounding prong from a cable. If you must use an extension cable, use an extension cable with properly grounded plugs.
- Observe extension cable and power strip ratings. Ensure that the total ampere rating of all products plugged into the extension cable or power strip does not exceed 80% of the ampere ratings limit for the extension cable or power strip.
- To protect the equipment from sudden, transient increase or decrease in electrical power, use a surge suppressor, line conditioner, or uninterruptible power supply (UPS).
- Do not modify power cables or plugs. Consult a licensed electrician or your power company for site modifications. Always follow your local/national wiring rules.
- To avoid possible damage to the system board, wait 5 seconds after turning off the system before removing a component from the system board or disconnecting a peripheral device.
- When connecting or disconnecting power to the hot-pluggable power supply units, observe the following guidelines:
 - ✓ Unplug the power cable before removing the power supply.
 - ✓ Install the power supply to the system before connecting the power cable to the power supply.
 - ✓ If the system has multiple sources of power, disconnect power from the system by unplugging all power cables from the power supplies.
- When disconnecting a cable, pull on its connector or on its strain-relief loop, and not on the cable itself.

Installation Assembly Safety Instructions

- The power supply in this product contains no user-serviceable parts. Refer servicing only to qualified personnel.
- Do not attempt to modify or use the supplied AC power cord if it is not the exact type required. A product with more than one power supply will have a separate AC power cord for each supply.
- To remove the AC power from the system, you must unplug each AC power cord from the wall outlet or power supply. The power cord(s) is considered the disconnect device to the main (AC) power. The socket outlet that the system plugs into shall be installed near the equipment and shall be easily accessible.
- A microprocessor and heat sink may be hot if the system has been running. Also, there may be sharp pins and edges on some board and chassis parts. Contact should be made with care. Consider wearing protective gloves.
- Danger of explosion if the battery is incorrectly replaced. Replace only with the same or equivalent type recommended by the equipment manufacturer. Dispose of used batteries according to manufacturer's instructions.
- The system is safety certified as rack-mounted equipment for use in a server room or computer room, using the customer rack kit. The rail racks are designed to carry only the weight of the system. Do not place additional load onto any rail-mounted equipment. System rack kits are intended to be installed in a rack by trained service technicians.

Site Selection

The system is designed to operate in a typical office environment. Choose a site that is:

- Clean and free of airborne particles (other than normal room dust).
- Well ventilated and away from sources of heat including direct sunlight and radiators.
- Away from sources of vibration or physical shock.
- Isolated from strong electromagnetic fields produced by electrical devices.
- In regions that are susceptible to electrical storms, we recommend you plug your system into a surge suppressor and disconnect telecommunication lines to your modem during an electrical storm.
- Provided with a properly grounded wall outlet.
- Provided with sufficient space to access the power supply cord(s), because they serve as the product's main power disconnect.
- Provided with either two independent AC power sources or two independent phases from a single source.

Equipment Handling Practices

Reduce the risk of personal injury or equipment damage:

- Conform to local occupational health and safety requirements when moving and lifting equipment.
- Use mechanical assistance or other suitable assistance when moving and lifting the equipment.
- To reduce the weight for easier handling, remove any easily detachable components.

Power and Electrical Warnings



CAUTION

- The power is active whenever the system is plugged in. To remove power from the system, you must unplug the AC power cord from the wall outlet. Your system may use more than one AC power cord. Make sure all AC power cords are unplugged. Make sure the AC power cord(s) is/are unplugged before you open the chassis, or add or remove any non hot-plug components.
- Do not attempt to modify or use an AC power cord if it is not the exact type required. A separate AC cord is required for each system power supply.
- The power supply in this product contains no user-serviceable parts. Do not open the power supply. Hazardous voltage, current and energy levels are present inside the power supply. Return to manufacturer for servicing.
- When replacing a hot-plug power supply, unplug the power cord to the power supply being replaced before removing it from the switch.

Power Cord Warnings

If an AC power cord was not provided with your product, purchase one that is approved for use in your country.



CAUTION

- To avoid electrical shock or fire, check the power cord(s) that will be used with the product as follows:
 - ✓ access can only be gained by SERVICE PERSONS or by USERS who have been instructed about the reasons for the restrictions applied to the location and about any precautions that shall be taken; and
 - ✓ access is through the use of a TOOL or lock and key, or other means of security, and is controlled by the authority responsible for the location.
- The power cord must have safety ground pin or contact that is suitable for the electrical outlet.
- The power supply cord(s) is/are the main disconnect device to AC power. The socket outlet(s) must be near the equipment and readily accessible for disconnection.
- The power supply cord(s) must be plugged into socket outlet(s) that is/are provided with a suitable earth ground.

System Access Warnings



CAUTION

- To avoid personal injury or property damage, the following safety instructions apply whenever accessing the inside of the product:
 - ✓ Turn off all peripheral devices connected to this product.
 - ✓ Disconnect the AC power by unplugging all AC power cords from the system or wall outlet.
 - ✓ Disconnect all cables and telecommunication lines that are connected to the system.
 - ✓ Retain all screws or other fasteners when removing access cover(s). Upon completion of accessing inside the product, refasten access cover with original screws or fasteners.
 - ✓ Do not access the inside of the power supply. There are no serviceable parts in the power supply. Return to the manufacturer for servicing.
 - ✓ Power down the switch and disconnect all power cords before adding or replacing any non hot-plug component.
 - ✓ When replacing a hot-plug power supply, unplug the power cord to the power supply being replaced before removing the power supply from the switch.
- Unless you are adding or removing a hot-plug component, allow the system to cool before opening the covers. To avoid the possibility of coming into contact with hot component(s) during a hot-plug installation, be careful when removing or installing the hot-plug component(s).
- To avoid injury do not contact moving fan blades. If your system is supplied with a guard over the fan, do not operate the system without the fan guard in place.

Rack Mount Warnings

The following installation guidelines are required by UL for maintaining safety compliance when installing your into a rack.

- The equipment rack must be anchored to an unmovable support to prevent it from tipping when a server or piece of equipment is extended from it. The equipment rack must be installed according to the rack manufacturer's instructions.
- Install equipment in the rack from the bottom up, with the heaviest equipment at the bottom of the rack.
- Extend only one piece of equipment from the rack at a time.
- You are responsible for installing a main power disconnect for the entire rack unit. This main disconnect must be readily accessible, and it must be labeled as controlling power to the entire unit, not just to the server(s).
- To avoid risk of potential electric shock, a proper safety ground must be implemented for the rack and each piece of equipment installed in it.
- Elevated Operating Ambient - If installed in a closed or multi-unit rack assembly, the operating ambient temperature of the rack environment may be greater than the room ambient. Therefore, consideration should be given to installing the equipment in an environment compatible with the maximum ambient temperature (T_{ma}) specified by the manufacturer.
- Reduced Air Flow - Installation of the equipment in a rack should be such that the amount of air flow required for safe operation of the equipment is not compromised.
- Mechanical Loading - Mounting of the equipment in the rack should be such that a hazardous condition is not achieved due to uneven mechanical loading.
- Circuit Overloading - Consideration should be given to the connection of the equipment to the supply circuit and the effect that overloading of the circuits might have on overcurrent protection and supply wiring. Appropriate consideration of equipment nameplate ratings should be used when addressing this concern.
- Reliable Earthing - Reliable earthing of rack-mounted equipment should be maintained.
- Particular attention should be given to supply connections other than direct connections to the branch circuit (e.g. use of power strips).

Other Hazards

Battery Replacement



CAUTION

- There is the danger of explosion if the battery is incorrectly replaced. When replacing the battery, use only the battery recommended by the equipment manufacturer.
- Dispose of batteries according to local ordinances and regulations.
- Do not attempt to recharge a battery.
- Do not attempt to disassemble, puncture, or otherwise damage a battery.

Cooling and Airflow



CAUTION

- Carefully route cables as directed to minimize airflow blockage and cooling problems. For proper cooling and airflow, operate the system only with the chassis covers installed. Operating the system without the covers in place can damage system parts. To install the covers:
 - ✓ Check first to make sure you have not left loose tools or parts inside the system.
 - ✓ Check that cables, add-in cards, and other components are properly installed.
 - ✓ Attach the covers to the chassis according to the product instructions.

Laser Peripherals or Devices



CAUTION

- To avoid risk of radiation exposure and/or personal injury:
 - ✓ Do not open the enclosure of any laser peripheral or device.
 - ✓ Laser peripherals or devices are not serviceable.
 - ✓ Return to the manufacturer for servicing.
 - ✓ Use certified Optical Fiber Transceiver Class 1 Laser Product.

Regulatory and Compliance Information

Electromagnetic Compatibility Notices

FCC Verification Statement (USA)1.5.1.1

This device complies with Part 15 of the FCC Rules. Operation is subject to the following two conditions: (1) this device may not cause harmful interference, and (2) this device may accept any interference received, including interference that may cause undesired operation.

This equipment has been tested and found to comply with the limits for a Class A digital device, pursuant to part 15 of the FCC Rules. These limits are designed to provide reasonable protection against harmful interference when the equipment is operated in a commercial environment.

This equipment generates, uses, and can radiate radio frequency energy and, if not installed and used in accordance with the instruction manual, may cause harmful interference to radio communications. However, there is no guarantee that interference will not occur in a particular installation. If this equipment does cause harmful interference to radio or television reception, which can be determined by turning the equipment off and on, the user is encouraged to try to correct the interference by one or more of the following measures:

- Reorient or relocate the receiving antenna.
- Increase the separation between the equipment and the receiver.
- Connect the equipment to an outlet on a circuit other than the one to which the receiver is connected.
- Consult the dealer or an experienced radio/TV technician for help.

Any changes or modifications not expressly approved by the grantee of this device could void the user's authority to operate the equipment. The customer is responsible for ensuring the compliance of the modified product.

Only peripherals (computer input/output devices, terminals, printers, etc.) that comply with FCC Class A or B limits may be attached to this computer product. Operation with noncompliant peripherals is likely to result in interference to radio and TV reception.

All cables used to connect to peripherals must be shielded and grounded. Operation with cables, connected to peripherals, that are not shielded and grounded may result in interference to radio and TV reception.

Europe (CE Declaration of Conformity)1.5.1.2

This product has been tested in accordance to, and complies with the Low Voltage Directive (73/23/EEC) and EMC Directive (89/336/EEC). The product has been marked with the CE Mark to illustrate its compliance.

VCCI (Japan)

この装置は、情報処理装置等電波障害自主規制協議会 (VCCI) の基準に基づくクラス A 情報技術装置です。この装置を家庭環境で使用すると電波妨害を引き起こすことがあります。この場合には使用者が適切な対策を講ずるよう要求されることがあります。

English translation of the notice above:

This is a Class A product based on the standard of the Voluntary Control Council for Interference (VCCI) from Information Technology Equipment. If this is used near a radio or television receiver in a domestic environment, it may cause radio interference. Install and use the equipment according to the instruction manual.

CCC Statement**声明**

此为 A 级产品，在生活环境中，该产品可能会造成无线电干扰
在这种情况下，可能需要用户对其干扰采取切实可行的措施

Regulated Specified Components

To maintain the UL listing and compliance to other regulatory certifications and/or declarations, the following regulated components must be used and conditions adhered to. Interchanging or use of other component will void the UL listing and other product certifications and approvals.

Updated product information for configurations can be found on the site at the following URL:
<http://www.QuantaQCT.com>

If you do not have access to the Web address, please contact your local representative.

- Add-in cards: must have a printed wiring board flammability rating of minimum UL94V-1.
- Add-in cards containing external power connectors and/or lithium batteries must be UL recognized or UL listed. Any add-in card containing modem telecommunication circuitry must be UL listed. In addition, the modem must have the appropriate telecommunications, safety, and EMC approvals for the region in which it is sold.
- Peripheral Storage Devices: must be UL recognized or UL listed accessory and TUV and VDE licensed. Maximum power rating of any one device is 19 watts. Total server configuration is not to exceed the maximum loading conditions of the power supply.

Restriction of Hazardous Substances (RoHS) Compliance

Quanta® Computer Inc. has a system in place to restrict the use of banned substances in accordance with the European Directive 2002/95/EC. Compliance is based on declaration that materials banned in the RoHS Directive are either (1) below all applicable threshold limits or (2) an approved / pending RoHS exemption applies.

RoHS implementation details are not fully defined and may change.

Threshold limits and banned substances are noted below:

- Quantity limit of 0.1% by mass (1000 PPM) for:
 - √ Lead
 - √ Mercury
 - √ Hexavalent Chromium
 - √ Polybrominated Biphenyls Diphenyl Ethers (PBDE)
- Quantity limit of 0.01% by mass (100 PPM) for:
 - √ Cadmium

End of Life / Product Recycling

Product recycling and end-of-life take-back systems and requirements vary by country. Contact the retailer or distributor of this product for information about product recycling and/or take-back.

Product Regulatory Compliance Markings

This product is marked with the following product certification markings:





Regulatory Compliance	Region	Marking
cULus Listing Marks	USA / Canada	
CE Mark	Europe	
FCC Marking (Class A)	USA	This device complies with Part 15 of the FCC Rules. Operation of this device is subject to the following two conditions: (1) This device may not cause harmful interference, and (2) This device must accept any interference received, including interference that may cause undesired operation.
VCCI Marking (Class A)	Japan	この装置は、情報処理装置等電波障害自主規制協議会 (VCCI) の基準に基づくクラス A 情報技術装置です。この装置を家庭環境で使用すると電波妨害を引き起こすことがあります。この場合には使用者が適切な対策を講ずるようにより要求されることがあります。
ICES	Canada	This Class A digital apparatus complies with Canadian ICES-003. Cet appareil numérique de la classe A est conforme à la norme NMB-003 du Canada.
Recycling Package Mark	Other than China	 
CCC	China	 <div style="border: 1px solid black; padding: 5px; display: inline-block;"> <p style="text-align: center;">警告</p> <p>此为A级产品，在生活环境中，该产品可能会造成无线电干扰。在这种情况下，可能需要用户对干扰采取切实可行的措施。</p> </div>

Table of Contents

SAFETY & REGULATORY INFORMATION	2
QuantaMesh T4000 Series	12
Chassis for the T4048-IX2 Switch	12
LED Indicators of T4048-IX2.....	13
Ports of T4048-IX2.....	14
Data Port Connection.....	15
Fan Tray of T4048-IX2.....	17
Power Supply of T4048-IX2.....	18
BMC of T4048-IX2	19
Airflow Direction	20
QuantaMesh T7000 Series	21
Chassis for the T7032-IX1/IX1B Switch	21
LED Indicators of T7032-IX1/IX1B	22
Ports of T7032-IX1/IX1B	23
Data Port Connection.....	24
Fan Tray of T7032-IX1/IX1B.....	25
Power Supply of T7032-IX1/IX1B.....	26
BMC of T7032-IX1B	27
Airflow Direction	28
Hardware Installation	29
Unpacking the Hardware	29
Package Contents	29
Installing the Switch	29
Site Survey	29
Positioning the Switch.....	30
Rack Mounting the Switch	30
Connecting to the Console Port	33
Connecting to the Management Port	34
Connecting the Power	35
AC Power Supply.....	35
Components Replacement	36
Troubleshooting	36
Diagnostic Switch Indicator	36
Power and Cooling Problems.....	36
Installation	36
In-Band Access	36
Replacing the Power Supply	37
Replacing the Fan Tray	39
Customer Support	39
Appendix	40
Manually Install Vendor OS	40

QuantaMesh T4000 Series

QuantaMesh T4048-IX2 supports 48 SFP28 (10/25GbE speed) ports and 8 QSFP28 (10/40 or 25/50/100GbE) in a compact rack unit size. By leveraging merchant silicon chip, the T4048-IX2 is a high performance, high density Ethernet switch for the deployment of data center infrastructure. With ONIE (Open Network Installation Environment) pre-loaded, the T4048-IX2 can be used with multiple network operating system that supports ONIE installer to achieve agile installation and fast response when demand changes.

Chassis for the T4048-IX2 Switch

Front panel

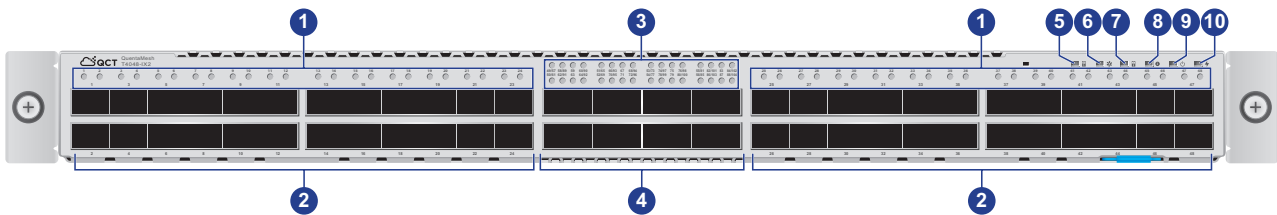

No.	Item
1	SFP28 Port LEDs
2	SFP28 Ports
3	QSFP28 Port LEDs
4	QSFP28 Ports
5	PSU1 LED

No.	Item
6	Fan LED
7	PSU2 LED
8	System info. LED
9	Power LED
10	BMC LED

Rear panel

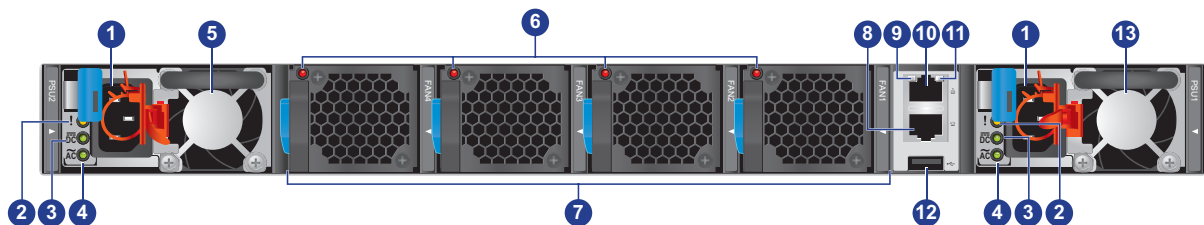

No.	Item
1	AC Power Connector (with Plug Retainer)
2	PSU Warning LED
3	PSU DC LED
4	PSU AC LED
5	PSU2
6	Fan LEDs
7	Hot-swappable Fan Modules

No.	Item
8	Console Port
9	Speed LED
10	Management Port
11	Link/Activity LED
12	USB Port
13	PSU1

LED Indicators of T4048-IX2

- System

System LED	Power	System Info	Fan	OOB Port	PSU1/2	BMC
Green	Powering On	Booting OK	Fans Working Good	100M (left LED)	Powering On	-
Amber	-	Booting On Going	-	1G (left LED)	-	-
Red	-	-	Fan Failed	-	Powering Failed	Switch System Fault
Off	Powering Failed	-	-	10M (left LED)	-	-
Blinking	-	-	-	Activity (right LED)	-	<ul style="list-style-type: none"> • Slow Blinking (Blue): BMC Healthy • Fast Blinking (Blue): Show BMC ID

- Data Port

Port Speed	SFP28	QSFP28
10G	Green	Green
25G	Amber	Amber
40G	-	Blue
50G	-	Yellow
100G	-	White
Activity	Blinking	Blinking

Ports of T4048-IX2

The switch chassis is equipped with the following ports:

- 48 SFP28 (10/25GbE speed)
- 8 QSFP28 ports (10/40 or 25/50/100GbE)
- 1 Management port
- 1 Console port
- 1 USB port

The chassis has 48 SFP28 and 8 QSFP28 ports. Each of these ports uses an optical transceiver, active optical cables, or direct-attached cable to connect the SFP28/QSFP28 port to servers and other Ethernet switches. For more information on obtaining the appropriate SFP28/QSFP28 modules, refer to [“Supported Cables and Transceivers” on page 15](#).

One management port enables you to manage the switch operation using an RJ-45 Ethernet cable.

One console port enables you to perform the initial configuration by connecting to a PC with the RJ-45 to DB-9 serial adapter cable.

One USB port provides the flexibility and possibility to install switch runtime image or configuration file into storage memory. Please contact with switch NOS vendor for more detail information.

Data Port Connection

Supported Cables and Transceivers

See the following table for the list of supported cables and transceivers.

Supported Distance	Description	Note
1m	10G Direct Attach Cooper (DAC) cable	SFP+ to SFP+
	10G Active Optical Cable (AOC)	SFP+ to SFP+
	25G Direct Attach Cooper (DAC) cable	SFP28 to SFP28
	25G Active Optical Cable (AOC)	SFP28 to SFP28
	40G Direct Attach Copper (DAC) cable	QSFP+ to QSFP+
	40G DAC fan out cable (to 4 x 10G)	QSFP+ to 4 SFP+
	100G Direct Attach Cooper (DAC) cable	QSFP28 to QSFP28
	100G Active Optical Cable (AOC)	QSFP28 to QSFP28
3m	10G Direct Attach Cooper (DAC) cable	SFP+ to SFP+
	10G Active Optical Cable (AOC)	SFP+ to SFP+
	25G Direct Attach Cooper (DAC) cable	SFP28 to SFP28
	25G Active Optical Cable (AOC)	SFP28 to SFP28
	40G Direct Attach Copper (DAC) cable	QSFP+ to QSFP+
	40G DAC fan out cable (to 4 x 10G)	QSFP+ to 4 SFP+
	100G Direct Attach Cooper (DAC) cable	QSFP28 to QSFP28
	100G DAC fan out cable (to 4 x 25G)	QSFP28 to SFP28
	100G Active Optical Cable (AOC)	QSFP28 to QSFP28
5m	10G Direct Attach Cooper (DAC) cable	SFP+ to SFP+
	10G Active Optical Cable (AOC)	SFP+ to SFP+
	25G Direct Attach Cooper (DAC) cable	SFP28 to SFP28
	25G Active Optical Cable (AOC)	SFP28 to SFP28
	40G Direct Attach Copper (DAC) cable	QSFP+ to QSFP+
	40G DAC fan out cable (to 4 x 10G)	QSFP+ to 4 SFP+
	100G Direct Attach Cooper (DAC) cable	QSFP28 to QSFP28
	100G Active Optical Cable (AOC)	QSFP28 to QSFP28
7m	40G Active Optical Cable (AOC)	QSFP+ to QSFP+
10m	40G Active Optical Cable (AOC)	QSFP+ to QSFP+
	100G Active Optical Cable (AOC)	QSFP28 to QSFP28
20m	40G Active Optical Cable (AOC)	QSFP+ to QSFP+
> 20m	10GBASE-SR SFP+ Transceiver Optic	SFP+
	25GBASE-SR SFP28 Transceiver Optic	SFP28
	40GBASE-SR4 QSFP+ Transceiver Optic (MPO)	QSFP+
	100GBASE-SR4 QSFP28 Transceiver Optic (MPO)	QSFP28
Up to 10km	40GBASE-LR4 QSFP+ Transceiver Optic (LC)	QSFP+
	100GBASE-LR4 QSFP28 Transceiver Optic (LC)	QSFP28

 **NOTE:**

- For more information about the cable/transceiver, please contact QCT sales.

SFP28 Port Connection

The switch is equipped with 48 SFP28 ports. The SFP28 ports support 10/25GbE IEEE 802.3ae Ethernet for fiber mediums.

The SFP28 ports are numbered and have corresponding SFP28 port LEDs.

To install an SFP28 module, do the following:

- 1 Slide the SFP28 module into an SFP28 port.



NOTE:

- Ensure the SFP28 module is positioned correctly before installing it into the port.

- 2 Push completely until the module locks into place.

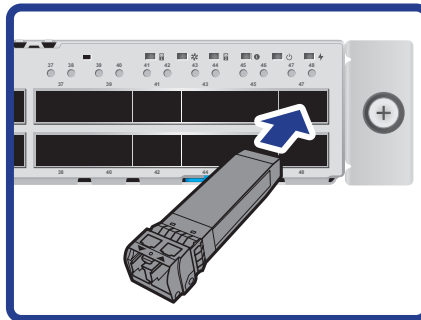

- 3 Repeat the above procedures to install additional SFP28 modules.

For more information about the SFP28 port LED behavior when the network link is established, refer to [“LED Indicators of T4048-IX2”](#) on page 13.

QSFP28 Port Connection

The switch is equipped with 8 QSFP28 ports. Each single port supports 40G or 100G by using 40G or 100G cables or optical transceivers. The switch can support fan-out cable for 40G to 4 x 10G or 100G to 4 x 25G or 2 x 50G.

The QSFP28 ports are numbered and have corresponding QSFP28 port LEDs.

To install a QSFP28 module, do the following:

- 1 Slide the QSFP28 module into a QSFP28 port.

- 2 Push completely until the module locks into place.

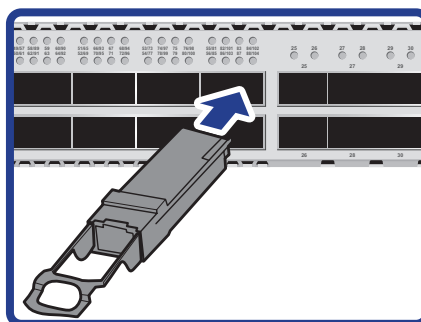

- 3 Repeat the above procedures to install additional QSFP28 modules.

For more information about the QSFP28 port LED behavior when the network link is established, refer to [“LED Indicators of T4048-IX2”](#) on page 13.

Fan Tray of T4048-IX2

The switch chassis is equipped with four fan trays. There are two types of hot-swappable fan modules. Each fan module handle is color-coded to indicate its airflow direction.

- Red: indicates front-to-back airflow.

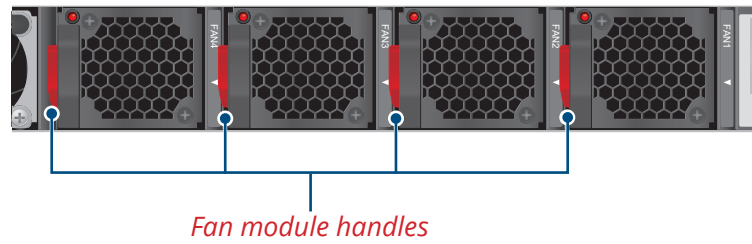

- Blue: indicates back-to-front airflow.

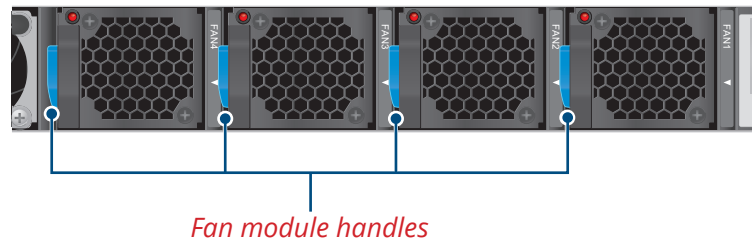

NOTE:

- To hot-swap the fan during operations, make sure to replace it within two minutes.

Power Supply of T4048-IX2

Equipped with two supply modules, the switch can operate with either one or two power supply modules. If the switch uses two power supply modules, you can hot-swap one of the PSU during the operations.

There are two types of PSU. Each plug retainer is color-coded to indicate its airflow direction.

- Red: indicates front-to-back airflow.
- Blue: indicates back-to-front airflow.

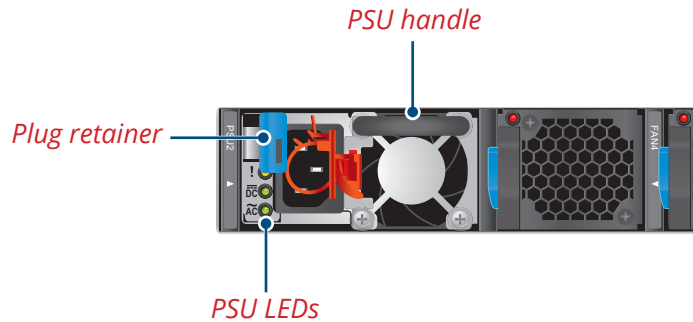

The AC power connector is a standard three-pronged connector. The switch automatically adjusts its power setting to any supply voltage in the range from 100~240 VAC at 50~60 Hz.



NOTE:

- *Verify that each module has the same airflow direction. Make sure the switch runs with all of its power supply and fan tray modules taking in air from a cold aisle and exhausting air to the hot aisle.*

Understanding the PSU LED

LED Type	LED Color	Function
Warning	Amber	PSU power / Thermal / Fan is not functioning properly.
AC	Green	The AC power (AC IN 220 / 110V) is operating normally.
	Off	The AC power (AC IN 220 / 110V) has failed.
DC	Green	The DC power (DC OUT +12V) is operating normally.
	Off	The DC power (DC OUT +12V) has failed.

BMC of T4048-IX2

T4048-IX2 has a built-in baseboard management controller (BMC) that plays the role of monitoring the whole system. The BMC is an independent subsystem with its own processor and memory so that it can run well even if the switch system hangs or powers down.

BMC Features

BMC supports the following features:

- Support IPMI v1.5 and v2.0 partial
- Serial over LAN
- HTTPS support
- Health status and hardware monitoring report
- Events log
- Event notification via LED indicator (on the chassis) and PET (Platform Event Trap)
- Platform Event Filtering (PEF) to perform the selected action
- Chassis management
- Watchdog, auto system re-start and auto recovery

To access BMC, the system allows the out-of-band management port which is shared between the switch and BMC. The system administrator can manage BMC remotely via Web by entering the its default IP address. By default, the BMC IP address is pre-configured to 192.168.0.120.

[\[BMC default IP address\]](#)

192.168.0.120

BMC supports two network connection options: Static IP and DHCP. For static IP connection, the administrator can change the BMC IP address via Web. Once the IP address is changed, re-login is required.

The console port is set only for the switch configuration. Although the hidden pin is accessible through the hole on the chassis, **it is reserved specifically for debugging purpose by the manufacturer and is not intended for end users operation.** The hidden pin is located in between 38 and 39 port LEDs as shown in the illustration below.

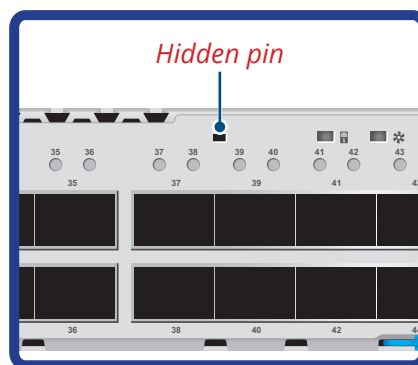

In addition, BMC also supports IPMI (Intelligent Platform Management Interface) protocol for the remote control. For more details of BMC configuration, please refer to its configuration guide.

Airflow Direction

The switch ships with four fan modules and two AC power supplies. The direction of the airflow varies depending on the color of the fan module handle/plug retainer.

- Red: indicates front-to-back airflow (air inlet module).
- Blue: indicates back-to-front airflow (air outlet module).



CAUTION

- Do not mix power supplies and fan modules with different airflow in the same chassis.

Front-to-Back Airflow

The air intake is located on the front panel of the switch. The cool air is sucked in from outside the chassis and pushed toward the rear of the chassis. The hot air exhausts through the vents on the rear panel of the switch.

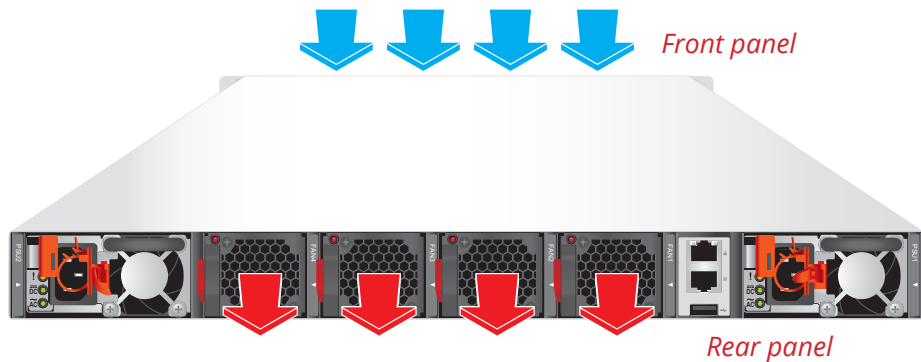

Back-to-Front Airflow

The air intake is located on the rear panel of the switch. The cool air is sucked in from outside the chassis and pushed toward the front of the chassis. The hot air exhausts through the vents on the front panel of the switch.

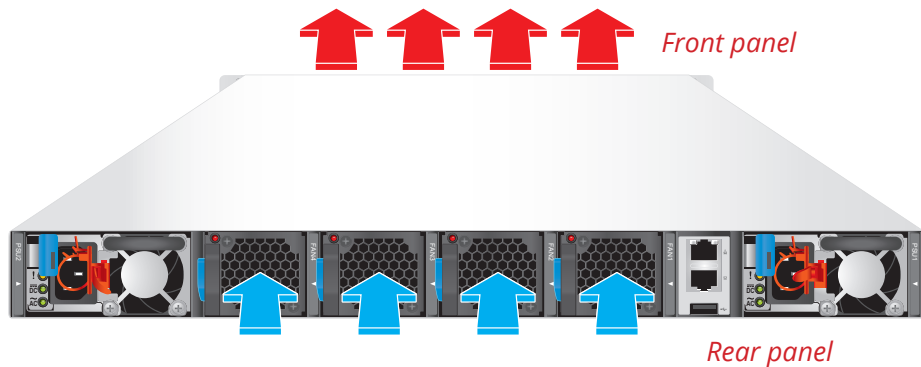

QuantaMesh T7000 Series

QuantaMesh T7032-IX1 supports 32 QSFP28 (10/40 or 25/50/100GbE speed) ports and QuantaMesh T7032-IX1B supports 32 QSFP28 (10/40 or 25/50/100GbE speed) ports and is equipped with BMC in a compact rack unit size. By leveraging merchant silicon chipsets, the T7032-IX1 and T7032-IX1B provides a high performance, high-density Ethernet switch at an affordable price. With ONIE (Open Network Installation Environment) pre-loaded, the T7032-IX1 and T7032-IX1B can be used with multiple operating system that support ONIE installers to achieve agile installation and fast response as demands change.

Chassis for the T7032-IX1/IX1B Switch

Front panel

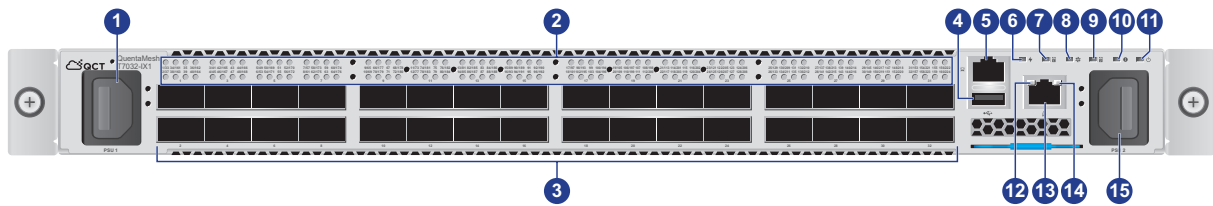

No.	Item
1	AC Power Connector (PSU1) with dust cover
2	QSFP28 Port LEDs
3	QSFP28 Ports
4	USB Port
5	Console Port
6	BMC LED (T7032-IX1B only)
7	PSU1 LED
8	Fan LED

No.	Item
9	PSU2 LED
10	System info. LED
11	Power LED
12	Speed LED
13	Management Port
14	Link/Activity LED
15	AC Power Connector (PSU2) with dust cover

Rear panel

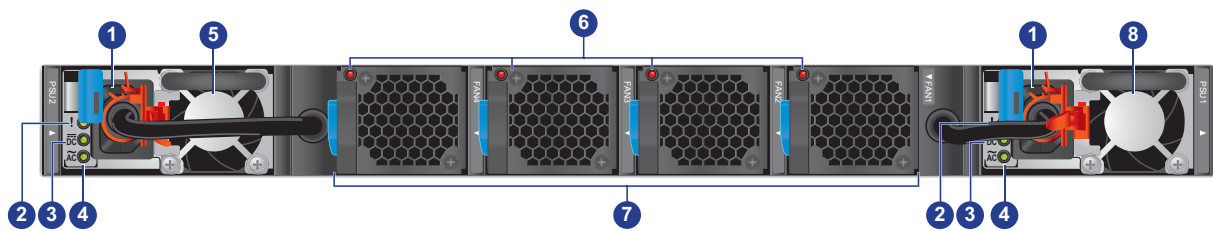

No.	Item
1	AC Power Connector (with Plug Retainer and Power Cord)
2	PSU Warning LED
3	PSU DC LED
4	PSU AC LED

No.	Item
5	PSU2
6	Fan LEDs
7	Hot-swappable Fan Modules
8	PSU1

LED Indicators of T7032-IX1/IX1B

- System

System LED	Power	System Info	Fan	OOB Port	PSU1/2	BMC
Green	Powering On	Booting OK	Fans Working Good	100M (left LED)	Powering On	-
Orange	-	Booting On Going		1G (left LED)	-	-
Red	-	-	Fan Failed	-	Powering Failed	-
Blue	-	-	-	-	-	Show BMC ID
Off	Powering Failed	Booting Failed	-	10M (left LED)	-	-
Blinking	-	-	-	Activity (right LED)	-	<ul style="list-style-type: none"> Blue (slow blinking): BMC Healthy Blue (rapid blinking): Show BMC ID Amber: Switch Event

- Data Port

Port Speed	QSFP28
10G	Green
25G	Amber
40G	Blue
50G	Yellow
100G	White
Activity	Blinking

Ports of T7032-IX1/IX1B

The switch chassis is equipped with the following ports:

- 32 QSFP28 ports (10/40 or 25/50/100GbE)
- 1 Management port
- 1 Console port
- 1 USB port

The chassis has 32 QSFP28 ports. Each of these ports uses an optical transceiver, active optical cables, or direct-attached cable to connect the QSFP28 port to servers and other Ethernet switches. For more information on obtaining the appropriate QSFP+ or QSFP28 modules, refer to [“Supported Cables and Transceivers” on page 24](#).

One management port enables you to manage the switch operation using an RJ-45 Ethernet cable.

One console port enables you to perform the initial configuration by connecting to a PC with the RJ-45 to DB-9 serial adapter cable.

One USB port provides the flexibility and possibility to install switch runtime image or configuration file into storage memory. Please contact with switch NOS vendor for more detail information.

Data Port Connection

Supported Cables and Transceivers

See the following table for the list of supported cables and transceivers.

Supported Distance	Description	Note
1m	40G Direct Attach Copper (DAC) cable	QSFP+ to QSFP+
	40G DAC fan out cable (to 4 x 10G)	QSFP+ to 4 SFP+
	100G Direct Attach Cooper (DAC) cable	QSFP28 to QSFP28
	100G Active Optical Cable (AOC)	QSFP28 to QSFP28
3m	40G Direct Attach Copper (DAC) cable	QSFP+ to QSFP+
	40G DAC fan out cable (to 4 x 10G)	QSFP+ to 4 SFP+
	100G Direct Attach Cooper (DAC) cable	QSFP28 to QSFP28
	100G DAC fan out cable (to 4 x 25G)	QSFP28 to SFP28
	100G Active Optical Cable (AOC)	QSFP28 to QSFP28
5m	40G Direct Attach Copper (DAC) cable	QSFP+ to QSFP+
	40G DAC fan out cable (to 4 x 10G)	QSFP+ to 4 SFP+
	100G Direct Attach Cooper (DAC) cable	QSFP28 to QSFP28
	100G Active Optical Cable (AOC)	QSFP28 to QSFP28
7m	40G Active Optical Cable (AOC)	QSFP+ to QSFP+
10m	40G Active Optical Cable (AOC)	QSFP+ to QSFP+
	100G Active Optical Cable (AOC)	QSFP28 to QSFP28
20m	40G Active Optical Cable (AOC)	QSFP+ to QSFP+
> 20m	40GBASE-SR4 QSFP+ Transceiver Optic (MPO)	QSFP+
	100GBASE-SR4 QSFP28 Transceiver Optic (MPO)	QSFP28
Up to 10km	40GBASE-LR4 QSFP+ Transceiver Optic (LC)	QSFP+
	100GBASE-LR4 QSFP28 Transceiver Optic (LC)	QSFP28

 **NOTE:**

- For more information about the cable/transceiver, please contact QCT sales.

QSFP28 Port Connection

The switch is equipped with 32 QSFP28 ports. Each single port supports 40G or 100G by using 40G or 100G cables or optical transceivers. The switch can support fan-out cable for 40G to 4 x 10G or 100G to 4 x 25G or 2 x 50G.

The QSFP28 ports are numbered and have corresponding QSFP28 port LEDs.

To install a QSFP28 module, do the following:

- 1 Slide the QSFP28 module into a QSFP28 port.
- 2 Push completely until the module locks into place.

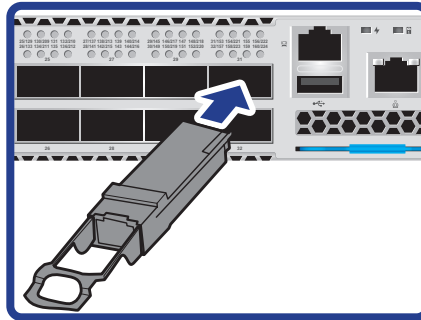

- 3 Repeat the above procedures to install additional QSFP28 modules.

For more information about the QSFP28 port LED behavior when the network link is established, refer to “LED Indicators of T7032-IX1/IX1B” on page 22.

Fan Tray of T7032-IX1/IX1B

The switch chassis is equipped with four fan trays. There are two types of hot-swappable fan modules. Each fan module handle is color-coded to indicate its airflow direction.

- Red: indicates front-to-back airflow.

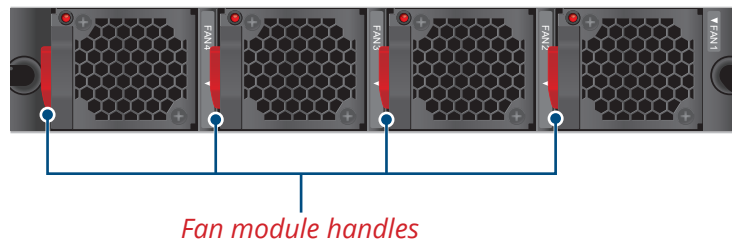

- Blue: indicates back-to-front airflow.

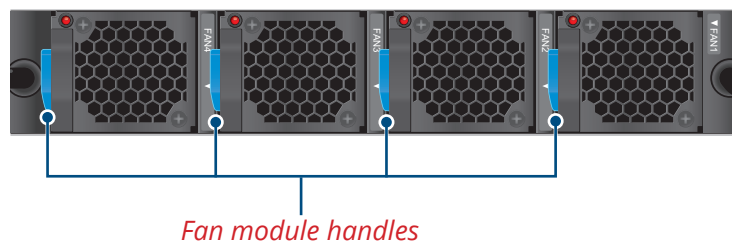

NOTE:

- To hot-swap the fan during operations, make sure to replace it within 30 seconds.

Power Supply of T7032-IX1/IX1B

Equipped with two supply modules, the switch can operate with either one or two power supply modules. If the switch uses two power supply modules, you can hot-swap one of the PSU during the operations.

There are two types of PSU. Each plug retainer is color-coded to indicate its airflow direction.

- Red: indicates front-to-back airflow.
- Blue: indicates back-to-front airflow.

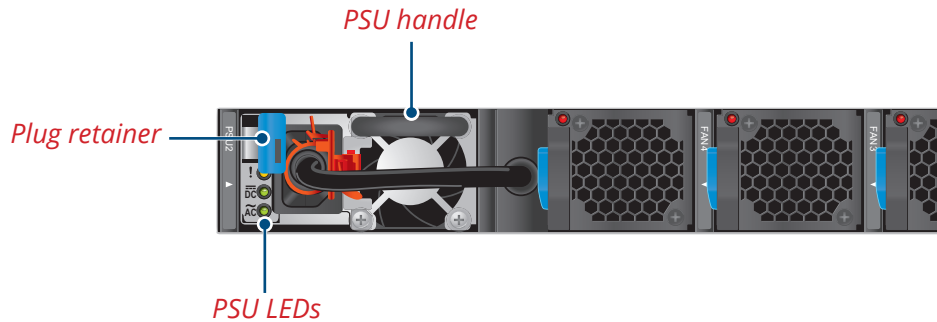

The AC power connector is a standard three-pronged connector. The switch automatically adjusts its power setting to any supply voltage in the range from 100~240 VAC at 50~60 Hz.



NOTE:

- *Verify that each module has the same airflow direction. Make sure the switch runs with all of its power supply and fan tray modules taking in air from a cold aisle and exhausting air to the hot aisle.*

Understanding the PSU LEDs

LED Type	LED Color	Function
Warning	Amber	PSU power / Thermal / Fan is not functioning properly.
AC	Green	The AC power (AC IN 220 / 110V) is operating normally.
	Off	The AC power (AC IN 220 / 110V) has failed.
DC	Green	The DC power (DC OUT +12V) is operating normally.
	Off	The DC power (DC OUT +12V) has failed.

About the AC Power Connector Connection

This switch has 2 AC power connectors on the front and rear panels. The power supply connection varies depending on the operating scenarios:

- If you are using the AC power connectors on the front panel for the power supply, make sure both power cords at the rear panel are properly connected. Then plug the power cables into the respective AC power connectors on the front panel.
- If you ONLY use the AC power connectors on the rear panel for the power supply, you have to unplug the power cords located at the rear panel first. Then plug the power cords into the respective AC power adapters, and plug the AC power adapters to a wall outlet.

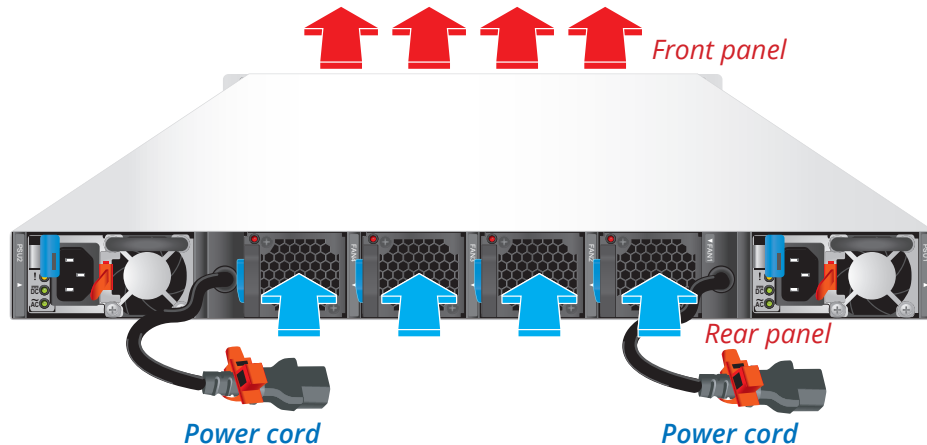

BMC of T7032-IX1B

T7032-IX1B has a built-in baseboard management controller (BMC) that plays the role of monitoring the whole system. The BMC is an independent subsystem with its own processor and memory so that it can run well even if the switch system hangs or powers down.

BMC Features

BMC supports the following features:

- Support IPMI v1.5 and v2.0 compliance
- Serial over LAN
- Support SNMP v1, v2 and v3
- Support SMASH
- HTTPS support
- Health status and hardware monitoring report
- Event log
- Event notification via LED indicator (on the chassis) and PET (Platform Event Trap)
- Platform Event Filtering (PEF) to perform the selected action
- Chassis management
- Watchdog, auto system re-start and auto recovery

To access BMC, the system allows the out-of-band management port which is shared between the switch and BMC. The system administrator can manage BMC remotely via Web by entering the its default IP address. By default, the BMC IP address is pre-configured to 192.168.0.120.

[BMC default IP address]
192.168.0.120

BMC supports two network connection options: Static IP and DHCP. For static IP connection, the administrator can change the BMC IP address via Web. Once the IP address is changed, re-login is required.

Airflow Direction

The switch ships with four fan modules and two AC power supplies. The direction of the airflow varies depending on the color of the fan module handle/plug retainer.

- Red: indicates front-to-back airflow (air inlet module).
- Blue: indicates back-to-front airflow (air outlet module).



CAUTION

- Do not mix power supplies and fan modules with different airflow in the same chassis.

Front-to-Back Airflow

The air intake is located on the front panel of the switch. The cool air is sucked in from outside the chassis and pushed toward the rear of the chassis. The hot air exhausts through the vents on the rear panel of the switch.

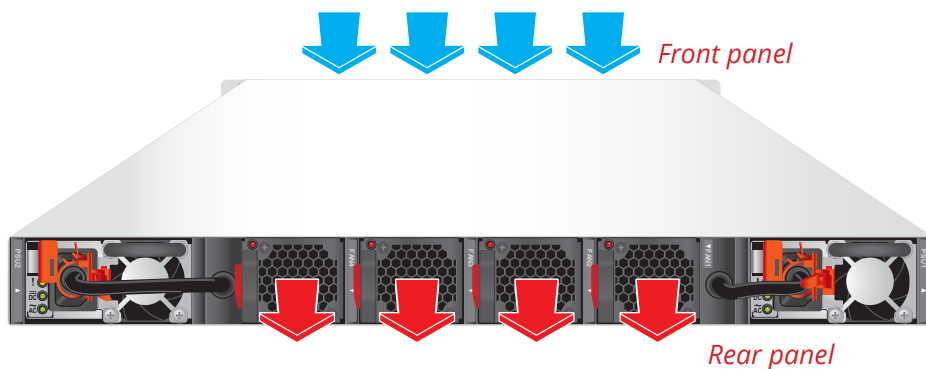

Back-to-Front Airflow

The air intake is located on the rear panel of the switch. The cool air is sucked in from outside the chassis and pushed toward the front of the chassis. The hot air exhausts through the vents on the front panel of the switch.

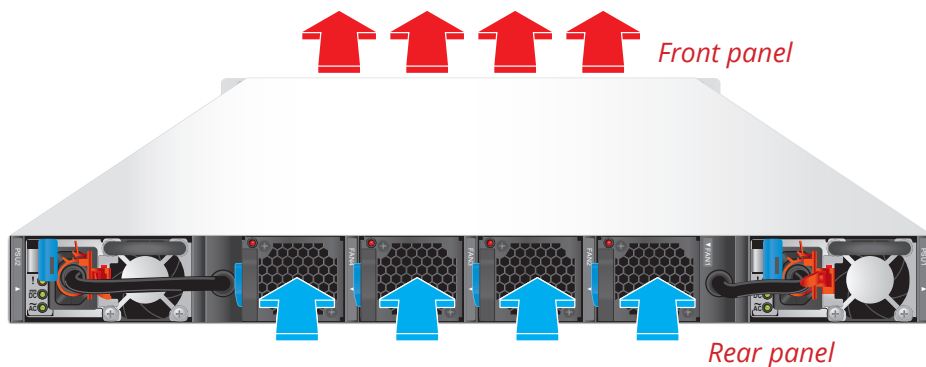

Hardware Installation

NOTE:

- *The examples used throughout this section are based on the T7032-IX1/IX1B switch (unless specified otherwise).*

Unpacking the Hardware

Upon receiving the switch, inspect the packing box. If the packing box was not damaged in transit, unpack it carefully.

NOTE:

- *Retain the packing box in case you need to transport the switch.*
- *The packing box is heavy. It is recommended for two persons to carry the box and perform the installation.*

Package Contents

The following items are included with a standard package. When you open the box, check if all items are included and free of damage.

- One QuantaMesh Ethernet switch
- Two AC power cords
- Console cable
- One set of rail kit
- Statement paper

It is important to ensure all items are included in the package before starting the installation.

- 1 Place the box on a flat and stable surface and cut the straps securing the box.
- 2 Carefully remove the switch. Then place it on a flat and clean surface.
- 3 Remove all other items from the box and inspect each item.

Installing the Switch

Site Survey

Consider the following when choosing a location to install the switch:

Installation Location

- Ensure that there is adequate space to allow you to access the front and rear panel ports for easy cable management and maintenance.
- Ensure that the site is located within a proper distance to the power source. The power source must be properly grounded and readily accessible.
- Ensure that the site is free from strong electromagnetic field sources, such as radiators, motors, and heat sources.
- Ensure that the site is not exposed to direct sunlight, rain or moisture.

Ventilation

- The installation surroundings must have adequate ventilation. Proper clearance between the switch and the wall or other equipment must be observed.

Rack Mounting

- If installing on a rack, verify the following:
 - ✓ Ensure the cabinet is stable and secure to withstand any unexpected movement, such as an earthquake.
 - ✓ Ensure the rack or cabinet can support the weight of the switch and other additional weight.

Positioning the Switch

The switch is equipped with Power Supply Units (PSU) and hot-swappable fan modules. It is important to determine the airflow direction of the power supply and fan modules before installing the switch.

Each fan module handle/plug retainer is color-coded to indicate its airflow direction.

- Red: indicates front-to-back airflow (air inlet module). See [“Front-to-Back Airflow” on page 28](#).
- Blue: indicates back-to-front airflow (air outlet module). See [“Back-to-Front Airflow” on page 28](#).

To ensure proper airflow, make sure that when you install the switch its air intake is positioned in a cold aisle and the air exhaust is positioned in a hot aisle for your data center.

NOTE:

- *Verify that each module has the same airflow direction. Make sure the switch runs with all of its power supply and fan tray modules taking in air from a cold aisle and exhausting air to the hot aisle.*

Rack Mounting the Switch

You can install the switch in most standard 19-inch (48.3-cm) racks.



CAUTION

- Due to the switch's weight, it should be installed by at least two people.

Items Required for Installation

The following items are required to install the switch onto the rack:

- ✓ Phillips screwdriver
- ✓ Screws that fit the equipment rack

Mounting the Switch into the Rack

1 Remove the inner rails.

Pull the inner rail out until it is fully extended (a), and then push the tab forward (b) to release the inner rail from the middle rail. Remove the inner rail.

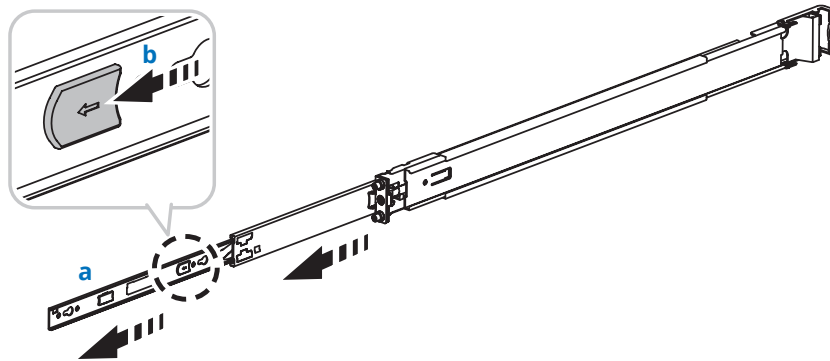

NOTE:

- Repeat the similar steps to remove another inner rail.

2 Install the inner rails on the switch.

Align the hooks on the switch and the holes in the inner rail, and then slide the inner rail backward until it is locked into place (a). Secure the inner rail to the switch with the screws (b).

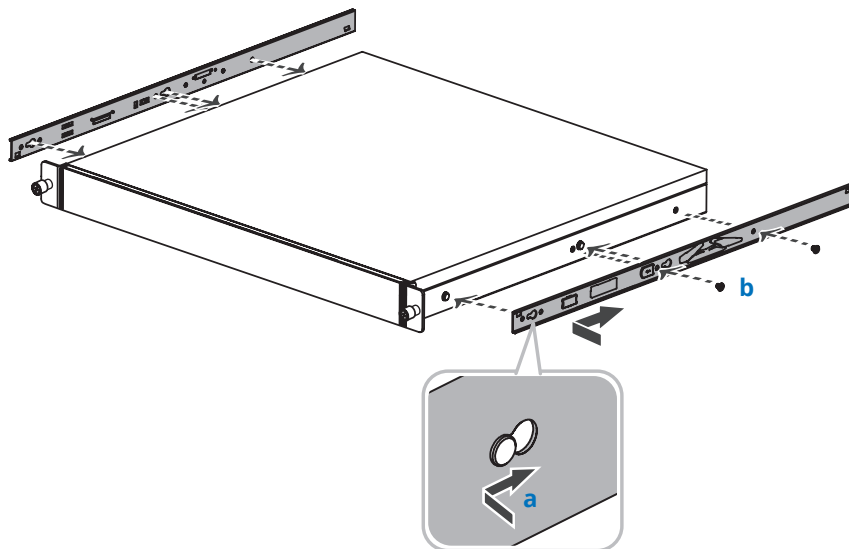

NOTE:

- Repeat the similar steps to install another inner rail.

3 Pull the tab upward to unlock the latch, and then push the middle rail back into the outer rail. Repeat the similar step to assemble another middle rail into the outer rail.

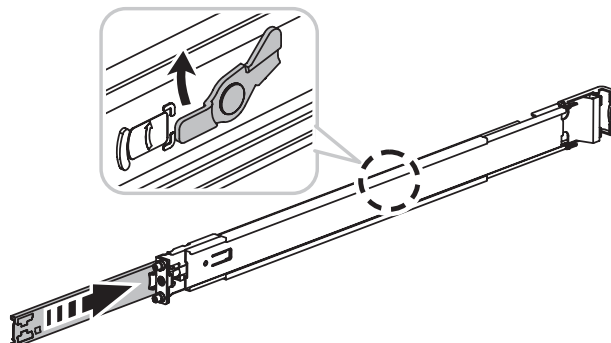

Hardware Installation

4 Install the outer rails to the rack.

- To install the rear bracket: Align and push the rail firmly into the rear rack until it clicks into place (a). Make sure the L-shaped bracket is facing inward.
- To install the front bracket: Pull the latch and install the rail by aligning the hooks with the front rack holes (b). Then release the latch to lock the hooks into place.

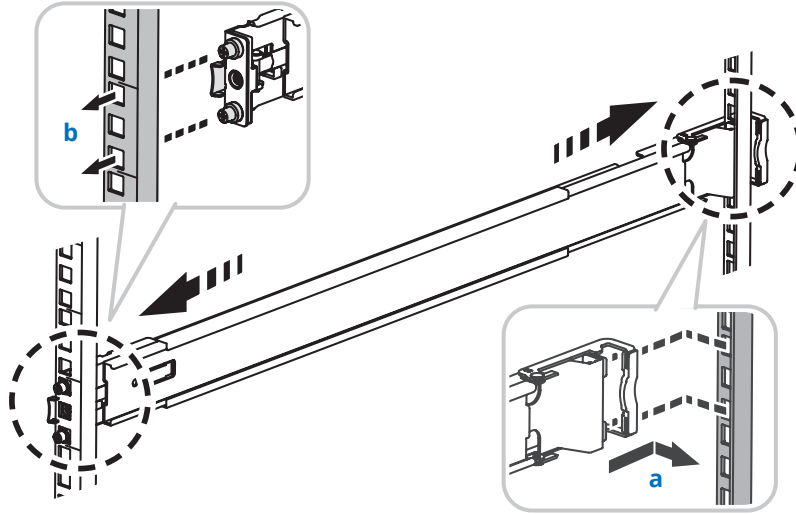

5 Mount the switch into the rack.

Pull the middle rail out until it is fully extended, ensuring the ball bearing retainer is locked at the front of the middle rail (a). Then slide the inner rails on the switch into the middle rails until it stops. Pull/push the blue release tab (b) on the inner rails and push the switch all the way to the rear of the rack.

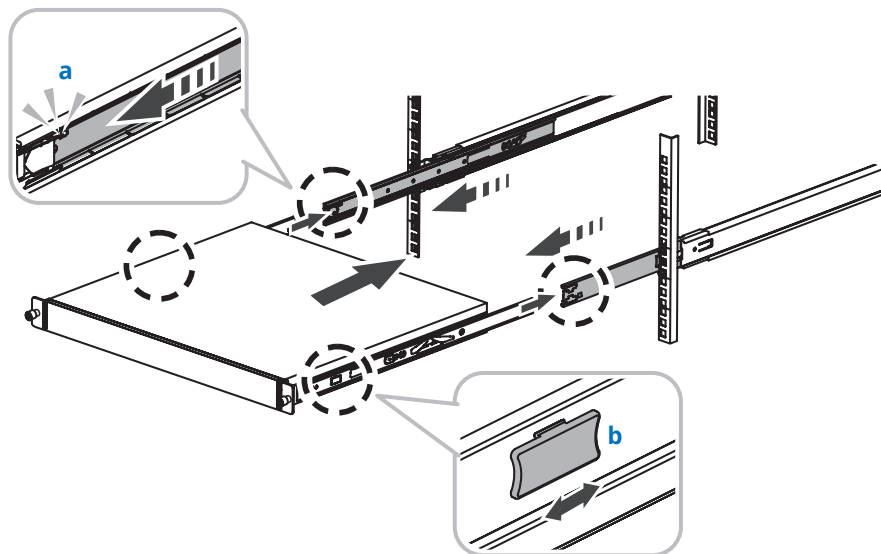

6 Secure the switch to the rack using the screws.

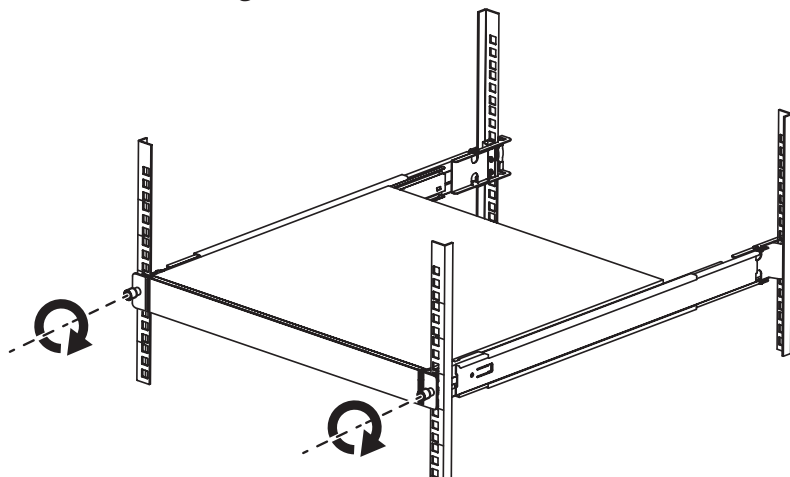

Connecting to the Console Port

The console port is used for setting up and managing the switch via a connection to a console terminal or PC using a terminal emulation program. You can connect the switch to a terminal or PC using the supplied console cable (RJ-45 male to RS-232 female cable) for serial communication.

Below is the console cable wiring specification table:

RJ-45 Port of Switch	DB9 Female Port of PC	Abbreviation	Description
3	2	RD	Received Data
6	3	TD	Transmit Data
1	8	CTS	Clear To Send
8	7	RTS	Request To Send
5	5	GND	Ground

Using the console port, you can perform the following:

- Configure the switch using the CLI commands
- Manage and monitor network activity by Command Line Interface (CLI) management
- Manage and monitor network activity by Simple Network Management Protocol (SNMP) management
- Upgrade the firmware

To connect to the console, do the following:

- 1 Connect the RJ-45 connector to the console port (🖨️) of the switch.

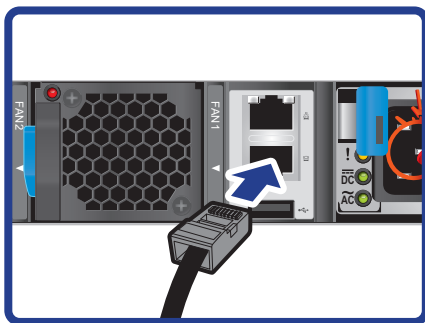

T4048-IX2

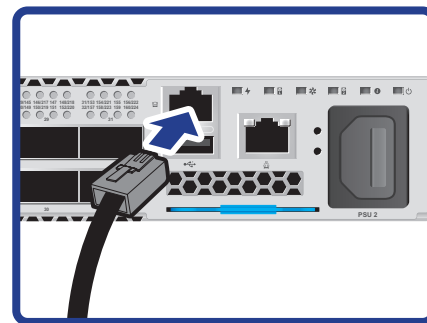

T7032-IX1/IX1B

- 2 Connect the RS-232 end to a terminal or PC.
- 3 Manage the switch using the CLI commands (refer to the CLI User Manual for more information).

The switch uses the following default settings:

- Baud rate: 115200
- Data width: 8 bits
- Parity: None
- Stop bits: 1
- Flow control: None

Connecting to the Management Port

The management port is a dedicated port interface which is segregated from data traffic crossing other downlink or uplink ports. The port supports auto-negotiation. If the attached device also supports auto-negotiation, the transmission can operate in either half or full duplex, and data rate can be in 10Mbps, 100Mbps, or 1Gbps. Telnet, SNMP, and Web browser utility can all go through this port for local or remote management after the IP address, subnet mask, and default gateway are properly configured.



CAUTION

- To avoid an IP address conflict, make sure to complete the initial configuration (see “Connecting to the Console Port” on page 33) before connecting the management port to the network. For more information on how to configure the switch, refer to the CLI User Manual.

To connect to the management port, do the following:

- 1 Connect one end of an Ethernet cable to the management port () of the switch.

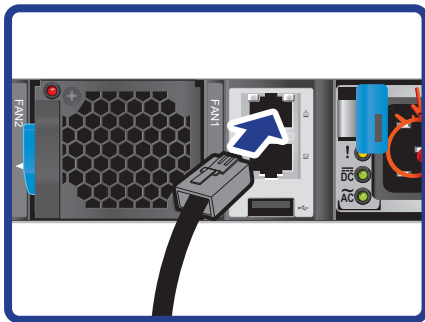

T4048-IX2

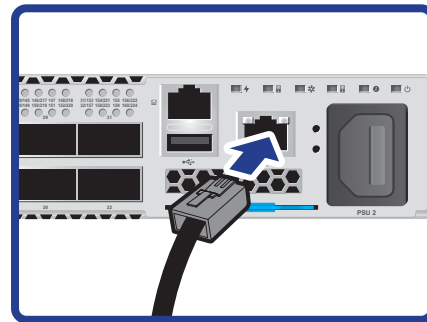

T7032-IX1/IX1B

- 2 Connect the other end of the Ethernet cable to a network.

The Management port LED (Link/Activity LED) lights green when the network link is established.

Connecting the Power

CAUTION

- Ensure that the socket outlet is installed near the equipment and be easily accessible.
- The power cord must have safety ground pin or contact that is suitable for the electrical outlet.
- The power supply cord(s) must be plugged into socket outlet(s) that is/are provided with a suitable earth ground.

AC Power Supply

The switch is equipped with two slots for power supplies. Depending on your needs, you may opt to use one or both PSUs at a time. Two circuits provide redundancy protection.

NOTE:

- Each PSU has an AC power connector.
- At least one power supply must connect to a power source.

To connect the switch to a power source, do the following:

- 1 Connect one end of the AC power cord to an AC power connector.

AC power connector

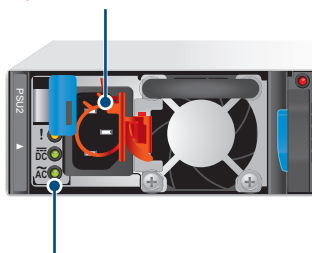

Power LEDs

T4048-IX2

AC power connector

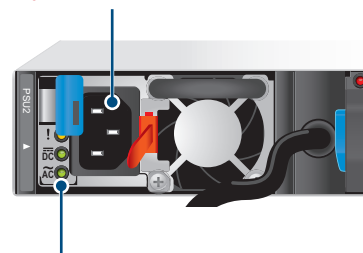

Power LEDs

T7032-IX1/IX1B

- 2 If you want to use two PSUs, connect another strip of AC power cord to the other AC power connector. Otherwise, skip this step.

- 3 Connect the other end(s) of the AC power cord(s) to the grounded power outlet(s).

The switch has no power button. Once an AC power cord is connected to a power outlet, the switch power is turned on. The Power LED lights green.

NOTE:

- This switch is equipped with 2 AC power connectors on the front and rear panels. Refer to *"About the AC Power Connector Connection"* on page 27.

Components Replacement

NOTE:

- The examples used throughout this section are based on the T7032-IX1/IX1B switch (unless specified otherwise).

Troubleshooting

Below is a list of the common problems that you may encounter when using the switch. Try to solve these problems with the suggested solutions before calling for service. If problems persist, contact customer support.

Diagnostic Switch Indicator

Problem	Solution
Power LED is off.	The switch does not receive any power. <ul style="list-style-type: none">• Check if the AC power cords are connected properly.• Check if the power supply units are completely seated in the chassis.• The power supply unit may be damaged and needs replacement.
A Port LED is off.	<ul style="list-style-type: none">• Check if the switch and the connected device are powered on.• Check if the connection in both ends are properly connected.• Check if the cable matches the required length and specification.• Check for a defective cable/port module.
PSU 1 & PSU 2 LED is in Red state.	Possible issues: <ul style="list-style-type: none">• Fan Lock (15 sec.)• OTP: Over Temperature Process• OCP: Over Current Process• OVP: Over Voltage Process• UVP: Under Voltage Process
Fan LED is in Red state.	One or more fans have failed.

Power and Cooling Problems

If the power indicator does not turn on when the power cord is plugged in, you may have a problem with the power outlet, power cord, or power supply. However, if the unit powers off after running for a while, check for loose power connections, power losses or surges at the power outlet, and verify that the fans on the unit are unobstructed and running prior to shutdown. If you still cannot isolate the problem, then the internal power supply may be defective.

Installation

Verify that all system components have been properly installed. If one or more components appear to be malfunctioning (such as the power cord or network cabling), test them in an alternate environment where you are sure that all the other components are functioning properly.

In-Band Access

You can access the management agent in the switch from anywhere within the attached network using Telnet, a Web browser, or other network management software tools. However, you must first configure the switch with a valid IP address, subnet mask, and default gateway. If you have trouble establishing a link to the management agent, check to see if you have a valid network connection. Then verify that you entered the correct IP address. Also, be sure the port through which you are connecting to the switch has not been disabled. If it has not been disabled, then check the network cabling that runs between your remote location and the switch.

Replacing the Power Supply

CAUTION

- When installing a new PSU, make sure it has the same airflow direction as the fan modules and the other power supply.
- For switches that only using a single power supply, removing the power supply will cause the switch to automatically shutdown.

The PSUs can be replaced without the use of special tools. Before replacing any of the PSUs, verify the status of the PSU to determine if there is a need for replacement.

NOTE:

- *In the event of a power supply failure, you can replace the defective unit without powering down the system, provided that there is at least one power supply must connect to a power source.*

To replace the power supply unit, do the following:

T4048-IX2 Switch

- 1 Disconnect the AC power cord of the PSU that you want to remove.
- 2 Press the plug retainer and then pull the handle to slide the PSU away from the chassis.



NOTE:

- *Take note of the part number of the removed PSU.*
 - *When making order for replacement modules, make sure that the part number of the new PSU is the same as the part number of the removed PSU.*
- 3 Ensure the power supply unit is correctly oriented, then install the new PSU into the chassis until it is firmly seated.
 - 4 Connect the AC power cord to power on the switch.

T7032-IX1/IX1B Switch

- 1 Disconnect the AC power cord of the PSU (on the rear panel) that you want to remove.

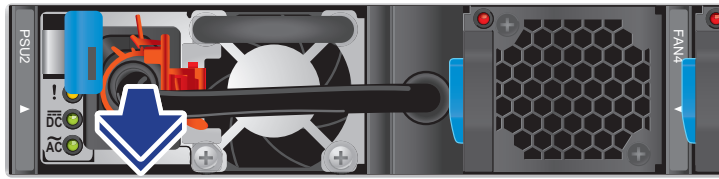

- 2 Press the plug retainer and then pull the handle to slide the PSU away from the chassis.

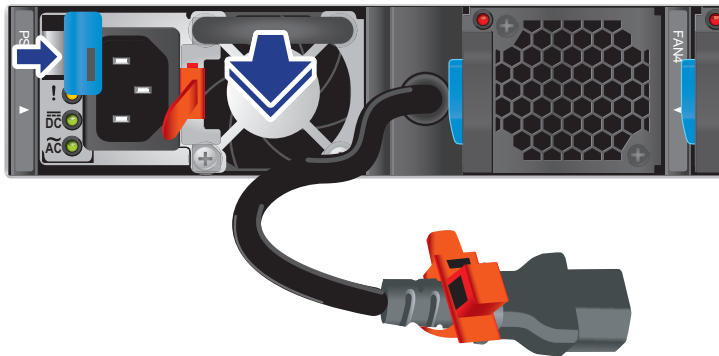

NOTE:

- Take note of the part number of the removed PSU.
 - When making order for replacement modules, make sure that the part number of the new PSU is the same as the part number of the removed PSU.
- 3 Ensure the power supply unit is correctly oriented, then install the new PSU into the chassis until it is firmly seated.
 - 4 Connect the AC power cord to power on the switch. Refer to [“About the AC Power Connector Connection”](#) on page 27.

Replacing the Fan Tray

CAUTION

- When installing a new fan module, make sure it has the same airflow direction as the fan modules and the power supply.

The fan modules can be replaced without the use of special tools. Before replacing any of the fan modules, verify the status of the fan modules to determine if there is a need for replacement.

NOTE:

- In the event of a fan failure, make sure to replace it within two minutes.

To replace the fan module, do the following:

- 1 Press the handle retainer and pull by the handle to slide the fan module away from the chassis.

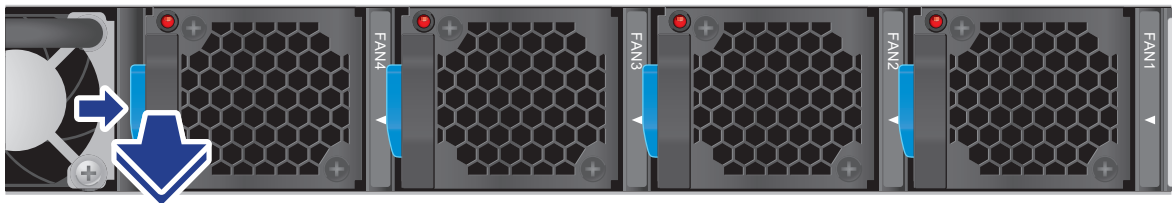

T4048-IX2

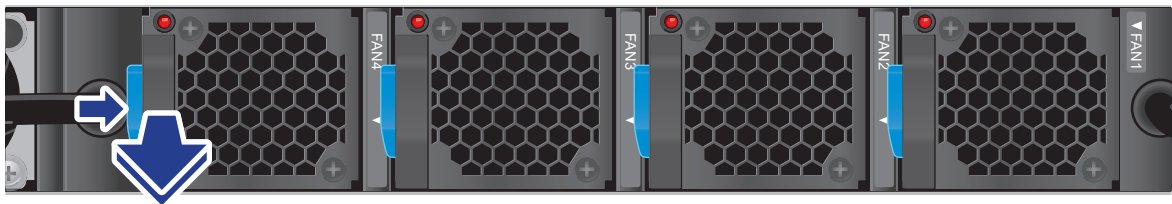

T7032-IX1/IX1B

NOTE:

- Take note of the part number of the removed fan module.
- When making order for replacement modules, make sure that the part number of the new fan module is the same as the part number of the removed fan module.

- 2 Ensure the fan module is correctly oriented, then install the new fan module into the chassis until it is firmly seated.

Customer Support

WARNING

There are no user-serviceable parts inside the PSU or hot-swappable fan module.

Do not disassemble any part of the PSU or hot-swappable fan module. Doing so voids the warranty and regulatory certifications.

For maintenance services not mentioned in this guide, please contact the manufacturer's customer support number as indicated on the warranty card.

Appendix

QuantaMesh Ethernet Switches support multiple NOS by using ONIE to install. The following pages provide example of how to manually install ONIE installer of Quanta NOS from QuantaMesh BMS devices.

Manually Install Vendor OS

With QUANTA ONIE code, it allows user to manually download an installer. You can use the *Download Installer* function which supports 3 types of different protocols (i.e. FTP, TFTP, and HTTP) to download the installer file from your local server.

To download and update the vendor OS code manually, perform the following:

- 1 Locate the specific QUANTA ONIE installer image that you want to download.

For example, the installer file name: **ly3-onie-installer-1.5.3**

- 2 Place the installer file into your local FTP, TFTP, or HTTP server.

For example, the server IP address: **192.168.2.153**

- 3 Go to ONIE Linux Shell.

a. Connect your PC and the switch using a console cable.

b. Enter ONIE Linux Shell.

```
Hit any key to stop autoboot: 0
Loading Open Network Install Environment ...
Platform: powerpc-quanta_ly3-r0
Version : 1.5.3-20131014174847
WARNING: adjusting available memory to 30000000
## Booting kernel from Legacy Image at 01000000 ...
   Image Name:   quanta_ly3-r0
   Image Type:   PowerPC Linux Multi-File Image (gzip compressed)
   Data Size:    3478939 Bytes = 3.3 MiB
   Load Address: 00000000
   Entry Point:  00000000
   Contents:
     Image 0: 2761944 Bytes = 2.6 MiB
     Image 1: 707476 Bytes = 690.9 KiB
     Image 2: 9503 Bytes = 9.3 KiB
   Verifying Checksum ... OK
## Loading init Ramdisk from multi component Legacy Image at 01000000 ...
## Flattened Device Tree from multi component Image at 01000000
Booting using the fdt at 0x134f0bc
Uncompressing Multi-File Image ... OK
Loading Ramdisk to 2ff53000, end 2ffffb94 ... OK
Loading Device Tree to 03ffa000, end 03fff51e ... OK
Cannot reserve gpages without hugetlb enabled
setup_arch: bootmem
quanta_ly3_setup_arch()
arch: exit

pci 0000:00:00.0: ignoring class b20 (doesn't match header type 01)

ONIE: Using default IPv4 addr: eth0: 192.168.3.10/255.255.255.0
cat: can't open '/var/run/onie/dhcp.logsrv': No such file or directory
discover: installer mode detected. Running installer.

Please press Enter to activate this console. To check the install status inspect /var/log/onie.log.
Try this: tail -f /var/log/onie.log

** Installer Mode Enabled **
ONIE:/ # ONIE: Using default IPv4 addr: eth0: 192.168.3.10/255.255.255.0
ONIE: Starting ONIE Service Discovery

ONIE:/ #
```

- c. Use the following command to stop ONIE service discovery:
"killall discover"

```
** Installer Mode Enabled **
ONIE:/ # ONIE: Using default IPv4 addr: eth0: 192.168.3.10/255.255.255.0
ONIE: Starting ONIE Service Discovery

ONIE:/ # killall discover
ONIE:/ #
```

d. Use the following command to set your switch box IP address:

```
"ifconfig eth0 192.168.2.1".
```

```
ONIE:/ #  
ONIE:/ # ifconfig eth0 192.168.2.1  
ONIE:/ #
```

- *ifconfig eth0*: the command string
- *192.168.2.1*: the switch IP address

e. Use the "**ipconfig**" command to verify if the IP address setting is correct.

```
ONIE:/ # ipconfig  
eth0      Link encap:Ethernet  HWaddr 00:C0:9F:01:02:03  
          inet addr:192.168.2.1  Bcast:192.168.2.255  Mask:255.255.255.0  
          UP BROADCAST RUNNING MULTICAST  MTU:1500  Metric:1  
          RX packets:0 errors:0 dropped:0 overruns:0 frame:0  
          TX packets:0 errors:0 dropped:0 overruns:0 carrier:0  
          collisions:0 txqueuelen:1000  
          RX bytes:0 (0.0 B)  TX bytes:0 (0.0 B)  
          Base address:0x8000  
  
ONIE:/ #
```

4 In ONIE Linux shell, use the "**install_url**" command to update the vendor OS code.

Use one of the following commands:

```
"install_url tftp://192.168.2.153/ly3-onie-installer-1.5.3"
```

or

```
"install_url ftp://192.168.2.153/ly3-onie-installer-1.5.3"
```

or

```
"install_url http://192.168.2.153/ly3-onie-installer-1.5.3"
```

- *install_url*: the command string
- *tftp/ftp/http*: use: the server protocol type
- *192.168.2.153*: the server IP address that stores the installer file
- *ly3-onie-installer-1.5.3*: the installer file